



Air Heater 5 L

Technical description
Installation instructions
Operating instructions
Maintenance instructions

Eberspächer

J. Eberspächer
GmbH & Co. KG
Eberspächerstr. 24
D - 73730 Esslingen

Telefon (zentral)
(07 11) 9 39 - 00
Telefax
(07 11) 9 39 - 05 00

www.eberspaecher.com

Engine-independent air heater 5 L for petrol fuel

Heater	Order no.
B 5 L C – 12 Volt	25 1735 05 00 00

Engine-independent air heater 5 L for diesel fuel

Heater	Order no.
D 5 L C – 12 Volt	25 1861 05 00 00
D 5 L C – 24 Volt	25 1862 05 00 00



**Please give this manual to the customer
after installation of the heater.**

1 Introduction

Contents

Chapter	Title	Contents	Page
1	Introduction	<ul style="list-style-type: none"> • Concept of this manual 3 • Special text structure, presentation and picture symbols 4 • Important information before starting work 4 • Statutory regulations 5, 6 • Safety instructions for installation and operation 6, 7 • Accident prevention 7 	
2	Product information	<ul style="list-style-type: none"> • Scope of supply 8, 9 • Technical data 10 • Main dimensions 11 	
3	Installation	<ul style="list-style-type: none"> • Installation and location 12 • Installing the 24 V heater in a vehicle for the transport of dangerous goods 12 • Installation location 13 • Possible installation positions 14 • Mounting and fastening 15 • Nameplate 16 • Heater air system 17 • Exhaust system 18 • Combustion air system 19 • Fuel supply 20 – 24 	
4	Operation and function	<ul style="list-style-type: none"> • Operating instructions/ important information for operation 25 • Initial commissioning 25 • Description of functions 26 • Control and safety devices / EMERGENCY OFF 27 	
5	Electrical system	<ul style="list-style-type: none"> • Heater wiring 28 • Parts list for the circuit diagrams 29 • Circuit diagrams at the end of this manual 	
6	Troubleshooting Maintenance Service	<ul style="list-style-type: none"> • In case of faults, please check the following points 30 • Troubleshooting 30 • Maintenance instructions 30 • Service 30 	
7	Environment	<ul style="list-style-type: none"> • Certification 31 • Disposal 31 • EU Declaration of Conformity 31 	
8	Lists	<ul style="list-style-type: none"> • List of key words 32, 33 • List of abbreviations 33 	



1 Introduction

Concept of this manual

This manual aims to support the service company installing the heater and to provide the user with all important information about the heater.

The manual has been divided into 8 chapters to make it easier to find the corresponding information quickly.

1 Introduction

Here you will find important introductory information about installation of the heater and about the structure of the manual.

2 Product information

Here you will find information about the scope of supply, the technical data and the dimensions of the heater.

3 Installation

Here you will find important information and instructions referring to installation of the heater.

4 Operation and function

Here you will find information about the operation and function of the heater.

5 Electric system

Here you will find information about the electronic system and electronic components of the heater.

6 Troubleshooting / maintenance / service

This section contains information on possible faults and malfunctions, troubleshooting, maintenance and the service hotline.

7 Environment

Here you will find information about certification and disposal of the heater together with the EU Declaration of Conformity.

8 Lists

Here you will find the key word list and abbreviations list.

1 Introduction

Special text structure, presentation and picture symbols

This manual uses special text structures and picture symbols to emphasise different contents. Please refer to the examples below for the corresponding meanings and associated actions.

Special structure and presentations

A dot (•) indicates a list which is started by a heading. If an indented dash (–) follows a dot, this list is subordinate to the dot.

Picture symbols

Regulation!

This picture symbol with the remark "Regulation" refers to a statutory regulation. Failure to comply with this regulation results in expiry of the type permit for the heater and preclusion of any guarantee and liability claims on J. Eberspächer GmbH & Co. KG.

Danger!

This picture symbol with the remark "Danger!" refers to the risk of a fatal danger to life and limb. Failure to comply with these instructions can result in severe injuries under certain circumstances.

Caution!

This picture symbol with the remark "Caution!" refers to a dangerous situation for a person and/or the product. Failure to comply with these instructions can result in injuries to people and/or damage to machinery.

Please note!

These remarks contain application recommendations and useful tips for installation of the heater.

Important information before starting work

Range of application of the heater

The air heater operating independently of an engine is intended for installation in the following vehicles, depending on its heating output:

- Vehicles of all kinds
- Construction machinery
- Agricultural machinery
- Boats, ships and yachts

Please note!

- The heater is not certified for installation in vehicle compartments used by passengers (more than 8 seats). Exception see page 5: statutory regulations, arrangement of the heater.
- Heater D 5 L C – 24 volt is allowed to be installed in vehicles used for the transport of dangerous goods as per ADR / ADR99.

Purpose of the heater

- Pre-heating, de-misting windows
- heating and keeping the following warm:
 - Driver and working cabs
 - Freight compartments
 - Ship's cabins
 - Passenger and crew compartments

On account of its functional purpose, the heater is not permitted for the following applications:

- Long-term continuous operation, e.g. for preheating and heating of:
 - Residential rooms
 - Garages
 - Work huts, weekend homes and hunting huts
 - House boots, etc.
- Heating or drying
 - living creatures (people or animals) by blowing hot air directly at the subject
 - objects
 - blowing hot air into containers

Caution!

Safety instructions for application and proper purpose!

- The heater must only be used and operated for the range of application stated by the manufacturer in compliance with the "Operating instructions" included with every heater.



1 Introduction

Statutory regulations

The heater has been awarded an "EC Type Permit" by the Federal Office for Motor Traffic with an official EC type permit sign shown on the heater nameplate, for installation of the heater in motorised vehicles.

air heater 5 L e100 0029



Regulation!

Directive 2001 / 56 / EU of the European Parliament and the Council

• Arrangement of the heater

- Parts of the structure and other components near the heater must be protected from excess heat exposure and possible contamination from fuel or oil.
- The heater must not pose a fire hazard even when it overheats.
This requirement is deemed to be fulfilled when adequate clearance to all parts is observed during installation, sufficient ventilation is provided and fire-proof materials or heat plates are used.
- The heater must not be mounted in the passenger compartment of vehicles in class M₂ and M₃.
But a heater in a hermetically sealed enclosure which otherwise complies with the conditions stated above may be used.
- The factory nameplate or duplicate must be affixed so that it can still be easily read when the heater is installed in the vehicle.
- All appropriate precautions must be taken when arranging the heater to minimise the risk of injuries to persons or damage to other property.

• Operating status display

- A clearly visible operating display in the user's field of vision must indicate when the heater is switched on and off.

• Fuel supply

- The fuel intake connection must not be located in the passenger compartment and must be sealed with a properly closing lid to prevent any fuel leaks.
- In heaters for liquid fuel where the heater fuel is separate from the vehicle fuel, the type of fuel and intake connection must be clearly identified.
- A warning sign is to be fixed to the intake connection indicating that the heater must be switched off before refuelling.

• Exhaust system

- The exhaust outlet must be arranged so as to prevent any penetration of exhaust fumes into the vehicle interior through the ventilation system, warm air intakes or open windows.

• Combustion air intake

- The air for the heater combustion chamber must not be sucked in from the passenger compartment of the vehicle.
- The air intake must be arranged or protected in such a way that it cannot be blocked by other objects.

• Heater air intake

- The heater air supply must consist of fresh air or circulated air and be sucked in from a clean area not contaminated by exhaust fumes of the drive machine, the combustion heater or any other source in the vehicle.
- The intake pipe must be protected by a grid or other suitable means.

• Hot air outlet

- The hot air pipes within the vehicle must be arranged or protected in such a way that there is no risk of injury or damage if they are touched.
- The air outlet must be arranged or protected in such a way that it cannot be blocked by any objects.

1 Introduction

Statutory regulations



Regulation!

Mounting the heater in a vehicle for the transport of dangerous goods as per ADR / ADR99

- When the heater is to be installed in vehicles for the transport of dangerous goods, the regulations of ADR / ADR99 must also be observed. Detailed information about the regulations of ADR / ADR99 are contained in the information leaflet no.25 2161 95 15 80 (see also page 12 and 27).

Please note!

- Compliance with the statutory regulations and safety instructions is prerequisite for guarantee and liability claims. Failure to comply with the statutory regulations and safety instructions and incorrect repairs even when using original spare parts make the guarantee null and void and preclude any liability for J. Eberspächer GmbH & Co. KG.
- Subsequent installation of this heater must comply with these installation instructions.
- The statutory regulations are binding and must also be observed in countries which do not have any special regulations.
- When the heater is to be installed in vehicles not subject to the German Ordinance for the Registration of Motor Vehicles (StVZO), for example ships, the specially valid regulations and installation instructions for these special applications must be observed.
- Installation of the heater in special vehicles must comply with the regulations applying to such vehicles.
- Other installation requirements are contained in the corresponding sections of this manual.

Safety instructions for installation and operation



Danger!

Risk of injury, fire and poisoning!

- The heater must only be started up when the maintenance flap is closed and the outlet hood is mounted in position.
- The maintenance flap must not be opened during operation.
- Disconnect the vehicle battery before commencing any kind of work.
- Before working on the heater, switch the heater off and let all hot parts cool down.
- The heater must not be operated in closed rooms, e.g. in the garage or in a multi-storey car park.
- Adjustable hot air outlets must always be adjusted so that they cannot blow hot air directly at living creatures (people, animals) or objects sensitive to temperature (loose and/or fastened).



Caution!

Safety instructions for installation and operation!

- The year of initial commissioning must be marked on the nameplate.
- The heat exchanger of air heaters is a component subject to high thermal loads which must be replaced 10 years after initial commissioning of the heater. In addition, the installation date must be entered on the plate "original spare part" enclosed with the heat exchanger must. Then affix the plate next to the nameplate on the heater.
- The heater must only be installed by a JE partner authorised by the manufacturer according to the instructions in this manual and possibly according to special installation recommendations; the same applies to any repairs to be carried out in the case of repairs or guarantee claims.
- Only the control elements approved by Eberspächer must be used to operate the heater. The use of other control elements can cause malfunctions.



1 Introduction

Safety instructions for installation and operation



Caution!

Safety instructions for installation and operation!

- Repairs by unauthorised third-parties or with not original spare parts are dangerous and therefore not allowed. They result in expiry of the type permit of the heater; consequently, when installed in motor vehicles they can cause expiry of the vehicle operating licence.
- The following measures are not allowed:
 - Changes to components relevant to the heater
 - Use of third-party components not approved by Eberspächer
 - Nonconformities in installation or operation from the statutory regulations, safety instructions or specifications relevant to safe operation as stated in the installation instructions and operating instructions. This applies in particular to the electrical wiring, fuel supply, combustion air system and exhaust system.
- Only original accessories and original spare parts must be used during installation or repairs.
- When carrying out electric welding on the vehicle, the plus pole cable at the battery should be disconnected and placed at ground to protect the controller.
- The heater must not be operated where there is a risk of an accumulation of flammable vapours or dust, for example close to
 - coal depot
 - wood depot
 - grain depots etc.
- The heater must be switched off when refuelling.
- When the heater is mounted in a safety housing etc., the installation compartment of the heater is not a stowage compartment and must be kept clear.
In particular fuel canisters, oil cans, spray cans, gas cartridges, fire extinguishers, cleaning rags, items of clothing, paper etc. must not be stored or transported on or next to the heater.

- Defect fuses must only be replaced by fuses with the prescribed rating.
- If fuel leaks from the heater fuel system, arrange for the damage to be repaired immediately by a JE service partner.
- After-running of the heater must not be interrupted prematurely e.g. by pressing the battery disconnecting switch, apart from in the case of an emergency stop.

Accident prevention

General accident prevention regulations and the corresponding workshop and operation safety instructions are to be observed.

2 Product information

Scope of supply for air heater B 5 L C

Quantity / Designation	Order number
1 B 5 L – 12 Volt	25 1735 05 00 00

to be ordered separately:

1 Universal installation kit	25 1861 80 00 00
1 Operating device 12 Volt*	25 1767 71 00 00
1 Cable harness for the operating device	22 1000 30 02 00

Scope of supply for air heater D 5 L C

Quantity / Designation	Order number
1 D 5 L – 12 Volt	25 1861 05 00 00
1 D 5 L – 24 Volt	25 1862 05 00 00

to be ordered separately:

1 Universal installation kit	25 1861 80 00 00
1 Operating device 12 volt*	25 1767 71 00 00
1 Operating device 24 volt*	25 1768 71 00 00
1 Cable harness for the operating device	22 1000 30 02 00

* Other controls (e.g. mini timer, module timer)
see price list or accessories catalogue

Parts list for the picture “Scope of supply” on page 9

Scope of supply for heater Picture-No. / Designation

1	Heater
2	Controller
3	Controller bracket
4	Dosing pump with integrated fuel filter
5	Current regulator
6	Bracket for current regulator
7	Combustion air silencer
8	Pipe clip
9	Cap

Scope of supply for universal installation kit Picture-No. / Designation

10	Cable tree heater
11	Flexible hose
12	Cable harness plus/minus
13	Cable harness dosing pump
14	Plus cable
15	Cable ties (10 ties)
16	Console for hot air hose
18	Grid
18	End sleeve for combustion air
19	Fuel hose 5 x 3
20	Fuel pipe 4 x 1,25
21	Fuel pipe 6 x 2
-	Connection parts
-	Electric connection parts
-	Fastening parts

Please note!

- Parts without picture number are small parts and packed in a bag.
- Please consult the additional parts catalogue if any other parts are required for installation.



2 Product information

Scope of supply

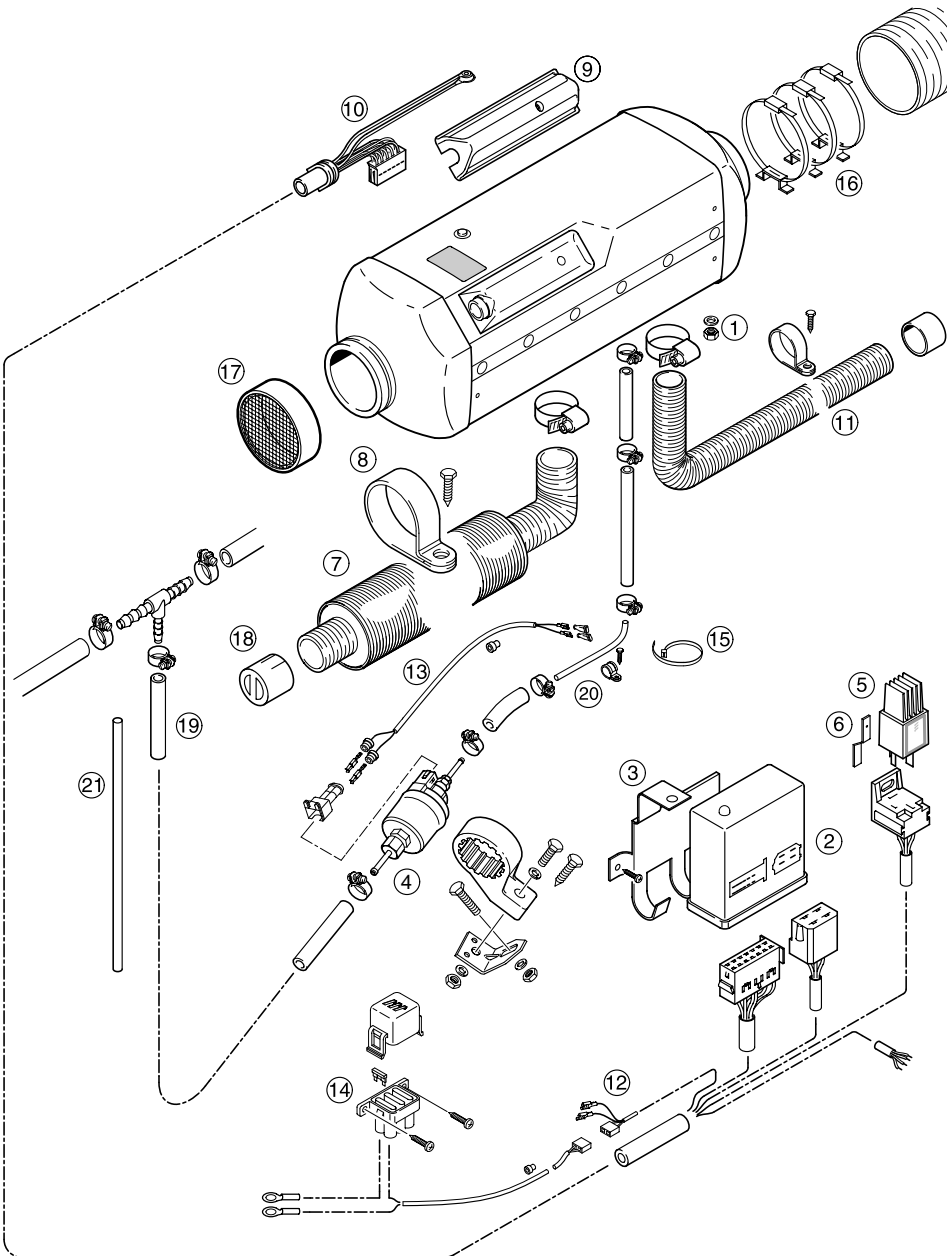

EN

FR

2 Product information

Technical data

Heater	B 5 L C				D 5 L C			
Heating medium	Air				Air			
Control of the heat flow	Stage				Stage			
	Power	Large	Medium	Small	Power	Large	Medium	Small
Heat flow (watt)	5500	4800	2700	2000	5500	4800	2700	1200
Heater air flow rate – without counterpressure (kg/h)	280	280	165	165	280	280	165	165
Heater code	10				10			
Fuel consumption (l/h)	0,74	0,65	0,37	0,27	0,68	0,58	0,34	0,15
Electr. power (watt)	in operation				in operation			
	80	80	40	40	80	80	40	40
	at start				at start			
Rated voltage	12 volt				12 or 24 volt			
Operating range Lower voltage limit: an undervoltage protection in the controller switches the heater off on reaching approx. 10 volt resp. 20 volt	10 volt resp. 20 volt Undervoltage protection trigger time: 20 seconds							
	Upper voltage limit: an undervoltage protection in the controller switches the heater off on reaching approx. 14 volt resp. 28 volt	14 volt resp. 28 volt Overvoltage protection trigger time: 20 seconds						
Fuel (page 24)		Petrol (DIN EN 228)				Diesel (DIN EN 590) Biodiesel PME (DIN V 51606)		
Tolerable operating temperature	heater		styrenhet		doserpump			
	operation petrol		-40 °C bis +50 °C		-40 °C bis +75 °C		-40 °C bis +20 °C	
	operation diesel		-40 °C bis +70 °C		-40 °C bis +75 °C		-40 °C bis +50 °C	
	storage		-40 °C bis +85 °C		-40 °C bis +85 °C		-40 °C bis +85 °C	
Noise emission – passenger compartment	The maximum noise pressure level is < 60 dB(A), measured in the operating mode power stage "large" as per 3. GGVS resp. DIN 45 635, part 1							
Maximum air intake temperature	+40 °C							
Interference suppression	Other measures possible							
Weight	ca. 8 kg							

EN



Caution!

Safety instructions for technical data!

Failure to comply with the technical data
can result in malfunctions.

All technical data + 10%

FR

2 Product information

Main dimensions

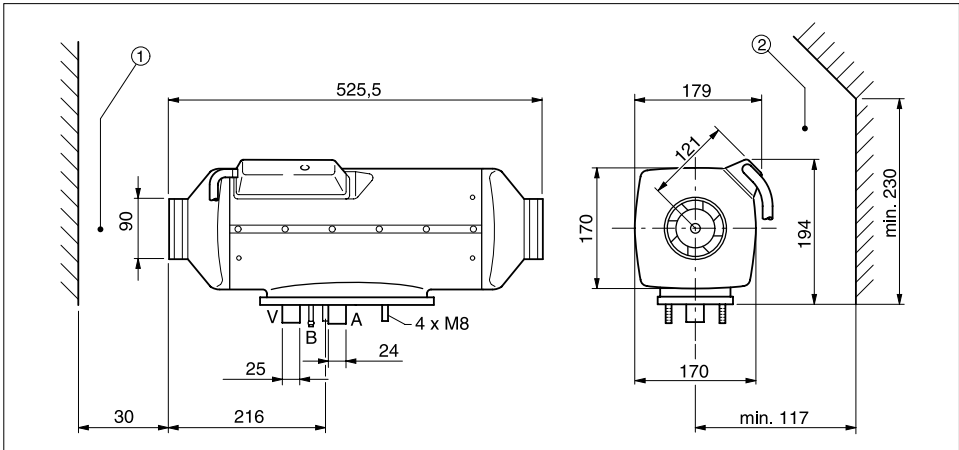

① Minimum installation clearance (space) for intake of heater air.

② Minimum installation clearance (free space) for glow plug.

A = exhaust

B = fuel

V = combustion air

3 Installation

Installation and location

The heater is suitable and certified for installation in parts of vehicles used by persons.
Installation in the cab or passenger compartments of coaches or buses with more than 9 seats is **not** allowed.

When installing in compartments used by persons, the exhaust, combustion air and fuel pipes in these areas must not have any detachable connections and must be routed splash-waterproof in the breakthroughs. For this reason, the heater can be mounted with its foot using the flange seal in the foot to the vehicle floor or to an outer wall of the vehicle.

The electronic control is integrated in the heater which makes wiring during installation much easier.

Please note!

- When fitting the heater, ensure there is sufficient space for heater air intake and for removing the glow plug and controller (see page 11, main dimensions).
- The regulations and safety instructions to be observed for this chapter are on page 4 – 7.

Installing the 24 V heater in a vehicle for the transport of dangerous goods as per ADR / ADR 99

The heater may be installed in vehicles used for the transport of dangerous goods as per ADR / ADR99.

Detailed information about the ADR / ADR99 regulations is contained in leaflet no. 25 2161 95 15 80.

Please note!

- For installation of the heater in vehicles for the transport of dangerous goods, the regulations of ADR / ADR99 must be observed.

3 Installation

Location

Installation in a car/van

In a van, the heater is preferably installed in the inner compartment or luggage compartment. If it cannot be installed in the inner compartment or luggage compartment, the heater can also be fitted to the vehicle floor from underneath.

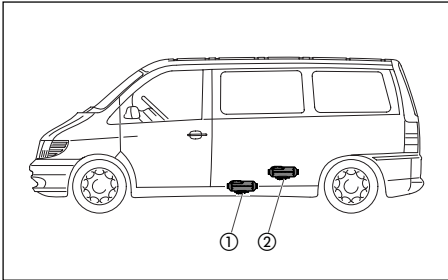

- ① Heater in the inner compartment
- ② Heater in the luggage compartment

Installation in a trailer

In a trailer, the heater is preferably installed in a box in the upper part of the front end.

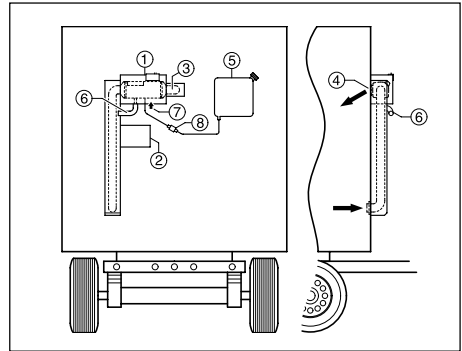

- ① Heater
- ② Battery
- ③ Flexible tube for heating air
- ④ Outflow for heating air
- ⑤ Extra fuel tank
- ⑥ Exhaust pipe
- ⑦ Combustion air
- ⑧ Fuel dosing pump

Please note!

- The installation suggestions made in the installation instructions are just examples. Other installation locations are possible, as long as they correspond to the installation requirements stated in these instructions.
- Other installation information (e.g. for boats and ships) is available from the manufacturer on request.
- Observe the tolerable installation position together with the operating and storage temperatures.

3 Installation

Possible installation positions

The heater is preferably installed in the normal position as shown in the drawing.

Depending on the installation conditions, the heater can be tilted by max. 30° (flow direction to the bottom) or turned by max. 90° around its own longitudinal axis (exhaust connection horizontal, glow plug points upwards!).

In the heating mode, the heater can deviate from the shown normal or maximum installation positions by up to +15° in all directions because of a slanting position of the vehicle or boat, without any impaired functions.

Normal position horizontal (exhaust connection downwards) with tolerable swivel range

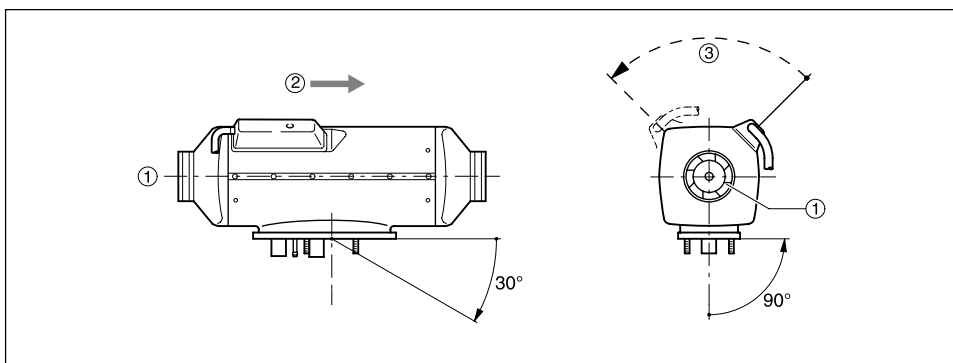

- ① Heater air intake opening (impeller)
- ② Direction of flow
- ③ Position of the glow plug

3 Installation

Mounting and fastening

Make the necessary breakthroughs for exhaust, combustion air and fuel as shown in the hole diagram. The support surface for the heater foot must be flat. An appropriate tool can be purchased from the manufacturer for drilling the breakthroughs and also smoothing the support surface.

The hole \varnothing 10.5 mm for the cable harness "dosing pump" is not included in the picture drawing and must be drilled after installation.

If the sheet metal of the support surface is thinner than 1.5 mm, an additional reinforcement plate will have to be fitted.

Order no: reinforcement plate 25 1729 89 00 03

Picture hole

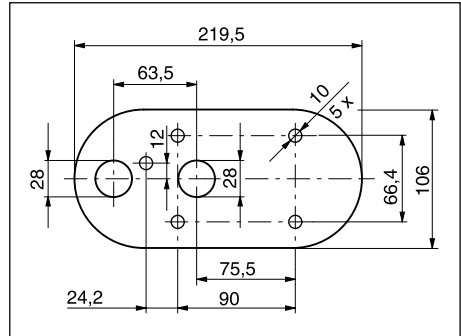

Fastening the unit on the vehicle floor

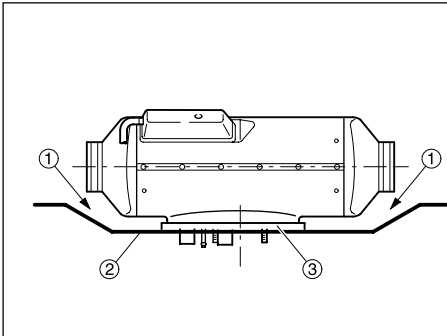

- ① There must be sufficient clearance between the heater and the vehicle floor – also check that the fan wheel runs freely.
- ② The mounting surface must be flat and smooth
- ③ The flange seal must be mounted

Fastening the heater horizontally to the vehicle wall

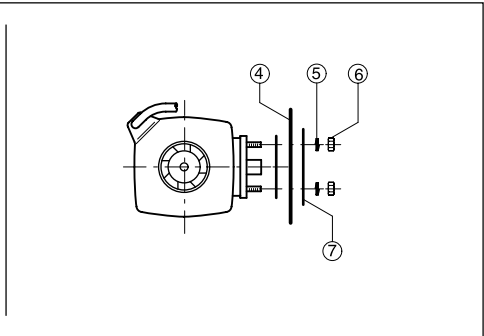

- ④ The vehicle wall must be flat and smooth
- ⑤ Spring washer
- ⑥ Hexagon nut M6 (torque 5⁺¹ Nm)
- ⑦ Reinforcement plate
(if required, order no. 25 1729 89 00 03)

3 Installation

Nameplate

The nameplate is fastened to the upper jacket shell. The second nameplate (duplicate) is included in the scope of supply of the heater and can be adhered as required in an easily visible position on the heater or near to the heater.

Please note!

The regulations and safety instructions to be observed for this chapter are stated on page 5.

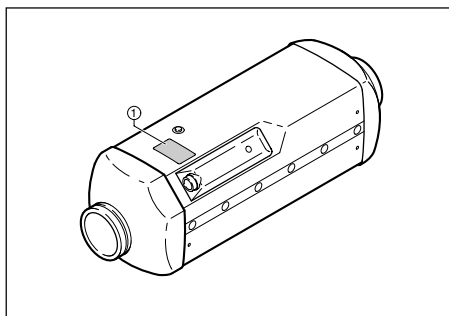

① Original nameplate

3 Installation

Heater air system

The scope of supply of the universal kit includes three consoles for the hot air system with cable ties and a safety grid.

For other air conveying parts, see extra parts catalogue.

Danger!

Risk of burning and injuries!

- The hoses of the heater air system and the hot air outlet are to be routed and fastened in such a way that they pose no temperature risk to people, animals or materials sensitive to temperature from radiation / contact or blowing directly. If necessary, a cover is to be fitted to the heater air system or hot air outlet.
- The outflow hood must be fitted on the hot air outflow side.
- A safety grid must be fitted to the heater air intake side and outflow side if no air hoses are mounted, to prevent any injuries from the heater air fan or burns from the heat exchanger.
- High temperatures occur in the heater air system during and after the heater has been working. This is why it is important to avoid working in the vicinity of the heater air system while the heater is working. In such cases, switch the heater off beforehand and wait until all parts have cooled down completely. If necessary, wear safety gloves.

Please note!

- The regulations and safety instructions to be observed for this chapter are on page 4 – 7.
- Note the equipment code in the technical data (page 10) when connecting up air-conveying parts.

Heater air system (example)

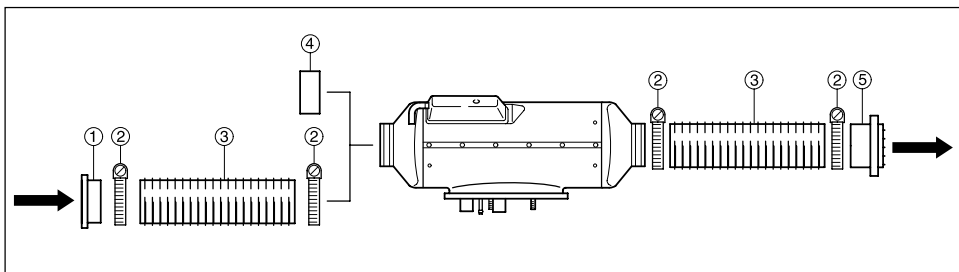

- ① Connection fitting with safety grid
- ② Hose clip
- ③ Flexible hose

- ④ Safety grid
- ⑤ Outflow

Caution!

- The heater air intake openings must be arranged in such a way that under normal circumstances, it is not possible for exhaust from the vehicle engine and heater to be sucked into the system, or for the heating air to be contaminated with dust, salt spray, etc.
- For circulating air, position the circulating air intake in such a way that the outflowing hot air cannot be directly sucked in again.
- In the event of possible overheating, increased heater air temperatures or surface temperatures can occur immediately before the defect shutdown.
- Only temperature-resistant hot air hoses approved by us must be used for the heater air system!
- When checking the functions, the mean outflow temperature measured after the heater has been running about 10 minutes at approx. 30 cm from the outlet should not exceed 110°C (at an intake temperature of approx. 20°C).

3 Installation

Exhaust system

(Exhaust diagram see page 19)

Mounting the exhaust system

The scope of supply of the universal kit includes a flexible exhaust pipe, inner diameter 24 mm, 1300 mm long. The flexible exhaust pipe can be shortened by 20 cm or lengthened to max. 2 m depending on the installation conditions.

In addition, an exhaust silencer can be inserted in the exhaust system. Fasten the exhaust silencer to the vehicle at a suitable point. Route the flexible exhaust pipe from the heater to the exhaust silencer and fasten with a pipe clip.

Route the flexible exhaust pipe from the heater to the exhaust silencer and fasten with pipe clips.

Connect an exhaust end pipe to the exhaust silencer and fasten with a pipe clip.

After finishing all installation work, place an end sleeve on the exhaust end pipe.



Caution!

Safety instructions!

The whole exhaust system gets very hot during and immediately after the heater has been working. This is the reason why the exhaust system must be installed according to these instructions.

- The exhaust outlet must end in the open air.
- The exhaust pipe must not protrude beyond the lateral limits of the vehicle.
- Install the exhaust pipe sloping slightly downwards. If necessary, make a drain hole approx. Ø 5 mm at the lowest point to drain off condensation.
- Important functional parts of the vehicle must not be impaired (keep sufficient clearance).
- Mount the exhaust pipe with sufficient clearance to heat-sensitive parts. Pay particular attention to fuel pipes (plastic or metal), electrical cables and brake hoses etc.!
- Exhaust pipes must be fastened safely (recommended clearance of 50 cm) to avoid damage from vibrations.
- Route the exhaust system so that the emitted fumes are not sucked in with the combustion air.
- The mouth of the exhaust pipe must not get clogged by dirt and snow.
- The mouth of the exhaust pipe must not point in the direction of travel.
- Always fasten the exhaust silencer to the vehicle.



Danger!

Risk of injuries and burns!

Every type of combustion produces high temperatures and toxic exhaust fumes. This is the reason why the exhaust system must be installed according to these instructions.

- Do not perform any work on the exhaust system while the heater is working.
- Before working on the exhaust system, first switch the heater off and wait until all parts have cooled down completely, wear safety gloves if necessary.
- Do not inhale exhaust fumes.

Please note!

- The regulations and safety instructions to be observed for this chapter are on page 4 – 7.
- If a silencer is fitted, the exhaust end pipe must be much shorter than the flexible exhaust pipe between the heater and the exhaust silencer.

3 Installation

Combustion air system

Mounting the combustion air system

The scope of supply of the heater includes a combustion air silencer which has to be mounted. The combustion air system can be extended up to max. 2 m if required with a connection pipe and a flexible combustion air hose, inner diameter 25 mm. (Order no. see extra parts catalogue).

Fasten the flexible combustion air hose to the heater with a pipe clip and to suitable places in the vehicle with hose clips or cable ties.

After completing all work, push an end sleeve over the flexible combustion air hose.

Please note!

- The regulations and safety instructions to be observed for this chapter are on page 4 – 7.



Caution!

Safety instructions for the combustion air system!

- The combustion air opening must be free at all times.
- Position the combustion air intake to be sure that exhaust fumes cannot be sucked in with the combustion air.
- Do not arrange the combustion air intake to pointing against the wind blast.
- The combustion air intake must not get clogged with dirt and snow.
- Install the combustion air intake system sloping slightly downwards. If necessary, make a drain hole approx. \varnothing 5 mm at the lowest point to drain off condensation.

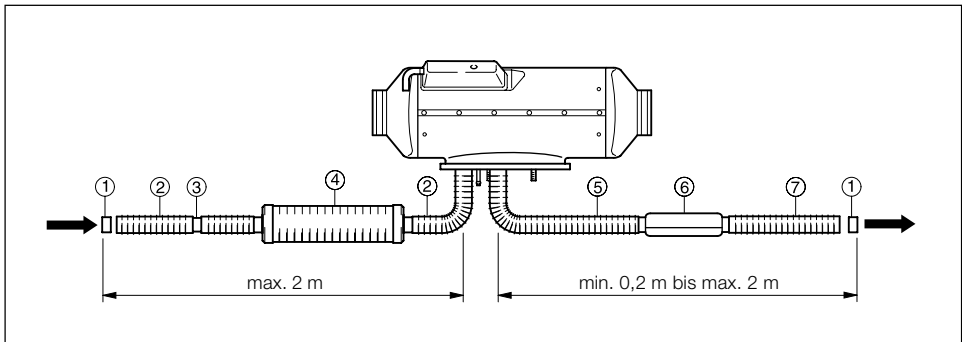

- ① End sleeve
- ② Combustion air hose, optional
- ③ Connection pipe, optional
- ④ Combustion air silencer
- ⑤ Flexible exhaust pipe, di = 24 mm
- ⑥ exhaust silencer, optional
- ⑦ exhaust pipe
- ⑧ combustion air connection
- ⑨ exhaust connection

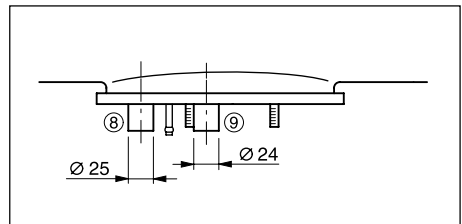

3 Installation

Fuel supply

Mounting the dosing pump, routing the fuel pipes and mounting the fuel tank

The following safety instructions must be observed when mounting the dosing pump, routing the fuel pipes and mounting the fuel tank. Deviations from the instructions stated here are not allowed.

Failure to comply can result in malfunctions.



Danger!

Risk of fire, explosion, poisoning and injuries!

Caution when handling fuel.

- Switch off the vehicle engine and heater before refuelling and before working on the fuel supply.
- No naked lights when handling fuel.
- Do not smoke.
- Do not inhale petrol fumes.
- Avoid any contact with the skin.



Caution!

Safety instructions for routing the fuel pipes!

- Only use a sharp knife to cut off fuel hoses and pipes. Interfaces must not be crushed and must be free of burrs.
- The fuel pipe from the dosing pump to the heater should be routed at a continuous rise.
- Fuel pipes must be fastened safely to avoid any damage and/or noise production from vibrations (recommended clearance of approx. 50 cm).
- Fuel pipes must be protected from any mechanical damage.
- Route the fuel pipes so that any distortion of the vehicle, engine movements etc. cannot have any lasting effect on the service life.

- Parts carrying fuel must be protected from interfering heat.
- Never route or fasten the fuel pipes to the heater or vehicle exhaust system. When the systems cross, always ensure there is a sufficient heat clearance. If necessary, install heat deflection plates.
- Dripping or evaporating fuel must never be allowed to collect on hot parts or ignite on electric systems.
- When connecting fuel pipes with a fuel hose, always mount the fuel pipes in a butt joint to prevent any bubbles from forming.

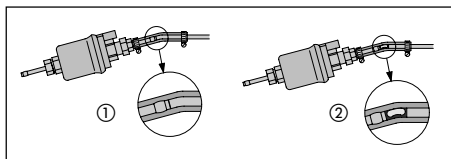

- ① correct connection
② incorrect connection – bubble formation



Safety instructions for fuel pipes and fuel tanks in buses and coaches

- In buses and coaches, fuel pipes and fuel tanks must not be routed through the passenger compartment or driver's cab.
- Fuel tanks in buses and coaches must be positioned in such a way that the exits are not in direct danger from a possible fire.

Please note!

- The regulations and safety instructions to be observed for this chapter are on page 4 – 7.

3 Installation

Fuel supply

Fuel feed point with T-piece from the fuel supply line from the tank fitting to the vehicle engine.

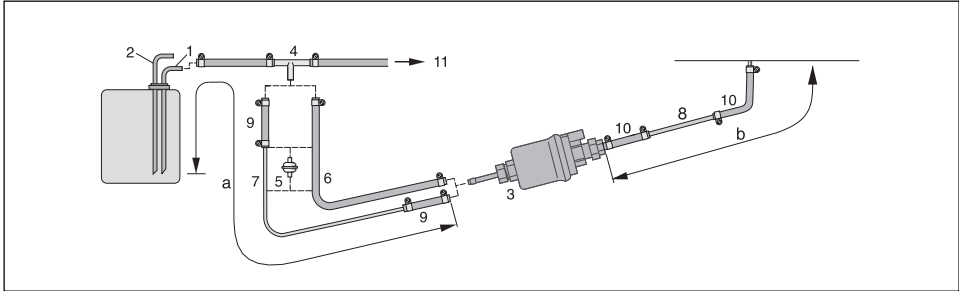

- ① Fuel feed pipe from tank connection
- ② Fuel return pipe to the tank connection
- ③ dosing pump
- ④ T-piece,
- ⑤ fuel filter – only necessary for contaminated fuel
- ⑥ fuel hose, 5 x 3 (di = Ø 5 mm)
- ⑦ fuel pipe, 6 x 2 (di = Ø 2 mm)
- ⑧ fuel pipe, 4 x 1,25 (di = Ø 1,5 mm)
- ⑨ fuel hose, 5 x 3 (di = Ø 5 mm), approx. 50 mm long
- ⑩ fuel hose, 3,5 x 3 (di = Ø 3.5 mm), approx. 50 mm long
- ⑪ to the engine, mechanical fuel or injection pump

Possible pipe lengths

Intake side
a = max. 2 m

Pressure side
b = max. 4 m for petrol
b = max. 6 m for diesel

Please note!

- Insert T-piece ④ before the fuel pump in the fuel feed pipe.
- Item ⑤ is not included in the scope of supply "installation kit". Order no. see extra parts catalogue.

Installation position of the T-piece

Use the installation positions shown in the diagram when inserting a T-piece

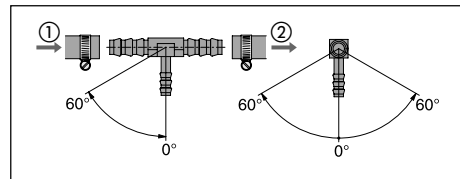

- ① direction of flow from the fuel tank
- ② direction of flow to the vehicle engine

3 Installation

Fuel supply

Fuel feed point with tank connection – ascending pipe, integrated in the vehicle tank or in the tank fitting

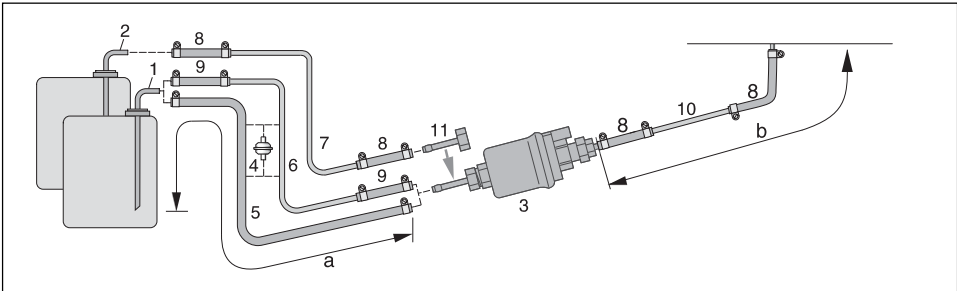

- ① tank connection for metal tank –
di = Ø 2 mm, da = Ø 6 mm
- ② tank connection for tank fitting –
di = Ø mm, da = Ø 4 mm
- ③ dosing pump
- ④ fuel filter – only required for contaminated fuel
- ⑤ fuel hose, 5 x 3 (di = Ø 5 mm)
- ⑥ fuel pipe, 6 x 2 (di = Ø 2 mm)
- ⑦ fuel hose, 4 x 1 (di = Ø 2 mm)
- ⑧ fuel hose, 3.5 x 3 (di = Ø 3.5 mm),
approx. 50 mm long
- ⑨ fuel hose, 5 x 3 (di = Ø 2 mm),
approx. 50 mm long
- ⑩ fuel pipe, 4 x 1.25 (di = Ø 1.5 mm)
- ⑪ connection fitting, da = Ø 4 mm

Possible pipe lengths

Intake side
a = max. 2 m

Pressure side
b = max. 4 m for petrol
b = max. 6 m for diesel

Please note!

Items ② ⑦ ⑪ are included in the “tank connection” kit.



Caution!

Safety instructions for the fuel supply!

- The fuel must not be conveyed by gravity or overpressure in the fuel tank.
- Withdrawal of fuel after the vehicle’s fuel pump is not allowed.
- When the pressure in the fuel pipe is more than 0.2 bar to max. 2 bar, use a pressure reducer (order no. 22 1000 20 09 00) or separate tank connection.
- When the pressure in the fuel pipe is more than 2 bar or there is a non-return valve in the return pipe (in the tank), a separate tank connection must be used.
- When using a T-piece in a plastic pipe, always use support sleeves in the plastic. Connect the T-piece and the plastic pipe with corresponding fuel hoses and secure with hose clips.

3 Installation

Fuel supply

Installation position of the dosing pump

Always mount the dosing pump with the pressure side rising upwards. Every installation position over 15° is allowed, although an installation position between 15° and 35° is preferable.

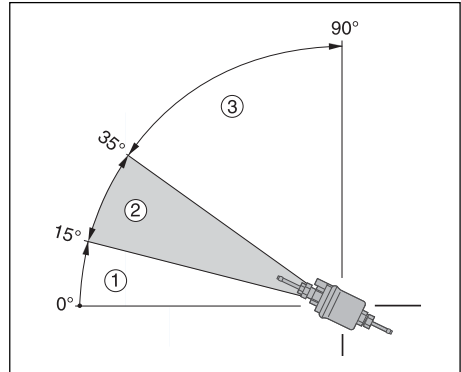

- ① installation position between 0° and 15° is not allowed.
- ② preferred installation position in range 15° to 35°
- ③ installation position in range 35° to 90° is allowed

Possible suction and pressure height of the dosing pump

Pressure height from vehicle tank to dosing pump:
a = max. 3000 mm

Intake height in pressure-less vehicle tank:
b = max. 500 mm for petrol
b = max. 1000 mm for diesel

Intake height in vehicle tanks with withdrawal by negative pressure (valve with 0.03 bar in tank cap):
b = max. 150 mm for petrol
b = max. 400 mm for diesel

Pressure height of the dosing pump to the heater:
c = max. 2000 mm

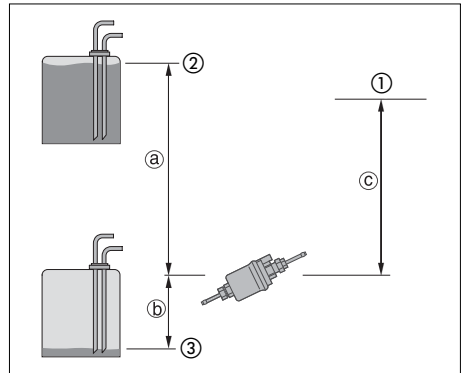

- ① connection to heater
- ② max. fuel level
- ③ min. fuel level

Please note!

Check tank venting.



Caution!

Safety instructions for installing the dosing pump

- Always mount the dosing pipe with the pressure side rising upwards – minimum incline 15°.
- Protect the dosing pump and filter from intolerable heat, do not mount near to the silencers and exhaust pipes.

3 Installation

Fuel supply

Fuel quality for petrol heaters

The heater can run on commercially available fuel as per DIN EN 228, as used in the vehicle tank.

Fuel quality for diesel heaters

The heater can run on commercially available diesel fuel as per DIN EN 590 as used in the vehicle tank.

Fuel for special cases

In special cases (above 0°C), the heater can also run on fuel oil EL or paraffin.

Fuel for low temperatures

Refineries and fuel service stations automatically adjust the fuel to normal winter temperatures (winter diesel). This means that difficulties are only to be expected for extreme drops in temperature, as also apply to the vehicle engine. Please also refer to the vehicle manual.

If the heater is run from a separate tank, please comply with the following rules:

For temperatures above 0°C, any kind of diesel fuel as per DIN EN 590 can be used.

If no special diesel fuel is available for low temperatures, then paraffin or petrol should be mixed with the fuel according to the following table:

Temperature	Winterdiesel	Addition
0 °C bis -25 °C	100 %	---
-25 °C bis -40 °C	50 %*	50 % paraffin or petrol

* or 100% special cold diesel fuel (Arctic diesel)

Operation with biodiesel (PME)

The heater is certified for running on biodiesel as per DIN V 51606 in free-flowing state (is reduced at temperatures under 0°C).

Please note!

- Mixtures with used oil are not allowed!
- After refuelling with winter or cold diesel or the listed blends, the fuel pipes and the dosing pump must be filled with the new fuel by letting the heater run for 15 mins.!



4 Operation and function

Operating instructions

The heater is controlled by the operating device (heating / ventilation).

The operating device is **not** included in the scope of supply. It is however necessary to operate the heater.

A heater timer can also be installed in addition to the operating device. The heating timer can be used to switch the heater on immediately, or the switching on time can be pre-selected from 24 hours up to 7 days, depending on the version. (Order no. for the heating timer see price list / accessories catalogue).

Please note!

The control elements (e.g. mini timer, module timer) are accompanied by detailed operating instructions which you will receive from the company installing the heater.

Important instructions for operation

Safety checks before the start

After a longer interval in operations (after the summer months) the fuse must be put in position and/or the heater connected up to the battery. Check that all parts fit firmly (tighten screws where necessary). Check the fuel system visually for any leaks.

Initial commissioning

- After installation of the heater, the coolant circuit and the whole fuel supply system must be vented carefully. Comply with the instructions issued by the vehicle manufacturer.
- During the trial run of the heater, check all water and fuel connections for leaks and firm fitting.
- If the heater shows a fault during operation, find and eliminate the cause of the fault using a diagnosis unit.

4 Operation and function

Operating instructions

Switching on.

When the operating device is switched on, the control lamp lights up.

The glow plug is switched on after approx. 3 seconds and the fan runs at full speed.

Starting the heater

After approx. 33 to 70 seconds, the fuel pump starts and the fuel/air mixture in the combustion chamber is ignited.

Once a stable flame has formed, the glow plug goes off.

To reach the operating temperature of the heat exchanger quickly, the heater runs at a higher heating output of 5.5 kW after switching on.

Once the operating temperature of the heat exchanger is reached, the heating output is reduced to 4.8 kW.

The time in which the heater runs at a higher heating output depends on the ambient temperature.

Control in heating mode

Once the intake or room temperature set at the operating device (10°C to 30°C) has been reached, the heater changes over to the "Small" stage and then runs on at the low speed of the fan motor.

If the heat flow of the "Small" stage of 1.2 kW or 2 kW is not sufficient, the heater switches over to the "Middle" stage. The fan runs on at low speed. In most cases, the control "Small - Middle - Small" at low speed is sufficient to cover most heating requirements.

If the heat flow of the "Middle" stage is not sufficient, the heater switches to the "Large" control stage. This means that the fan motor now runs at full speed. If in certain cases even less heat flow is required than produced in the "Small" stage, the heater switches to "OFF".

This is followed by an after-running period and constant re-ventilation through to re-start (only for circulation air mode). Re-start is in the "Middle" stage at low speed of the fan motor.

Ventilating mode

If the heater is adjusted to "Ventilation" at the operating device, the fan runs at full speed

Switching off

When the heater is switched off, the control lamp goes off and the fuel supply is switched off.

The fan runs on for approx. 4 – 5 minutes to cool down.



4 Operation and function

Control and safety devices

The flame is monitored by the flame sensor, and the maximum permissible temperature by the overheating switch. Both influence the controller which switches the heater off for any faults.

- If the heater does not ignite within 90 seconds after starting the fuel pump, the start is repeated as described.
If the heater still does not ignite after another 90 seconds fuel pumping, the heater is switched off.
- If the flame goes off by itself during operation, the heater is restarted.
If the heater does not ignite within 90 seconds after the fuel pump has started again, or it ignites but goes off again within 10 minutes, the heater is switched off.
This status can be remedied by briefly switching off and on again.
- In the case of overheating, the overheating sensor triggers, the fuel supply is interrupted and the heater switched off. If overheating has caused the heater to be switched off, the switch-on control lamp (green) in the operating device flashes at uniform intervals.
Other fault display signals can be displayed with additional accessories, see troubleshooting and repair instructions. Once the cause of overheating has been eliminated, the heater can be started again by switching off and on again.
- If the voltage falls below approx. 10 or 20 volt, or if it increases above approx. 14 or 28 volt, the heater is switched off.
- The heater will not start when the glow plug is defect or when the electric lead to the dosing pump is interrupted.

- When the heater starts up, the function of the fan motor is checked once. If it does not start, the heater is switched off.
During operation, the fan motor is monitored in cycles (4 minutes). If the motor speed exceeds the permissible limit, the heater is switched off.
- When the heater is switched off, the glow plug is switched on for approx. 30 seconds while the fan is still running (post glowing) to clean it from any combustion residues.

Please note!

- Do not switch the heater off and on again more than twice.

Forced shut-down for ADR / ADR99 operation

In vehicles for the transport of dangerous goods (e.g. tanker trucks), the heater must be switched off before the truck drives into a danger area (refinery, fuel service station, etc.)

Failure to comply results in the heater switching off automatically when:

- the vehicle engine is switched off
- an additional unit is started up (e.g. auxiliary drive for unloading pump etc.)
- a vehicle door is opened (ADR99 regulation, only in France).

The fan then runs on for max. 40 seconds.

Emergency shutdown – EMERGENCY OFF

If an emergency shutdown – EMERGENCY OFF – is necessary during operation, proceed as follows:

- Switch the heater off with the control or
- Pull the fuse out or
- Disconnect the heater from the battery.

5 Electrical system

Heater wiring



Caution!

Safety instructions for wiring the heater!

The heater is to be connected up electrically according to the EMC directives.

EMC can be affected if the heater is not connected up correctly. For this reason, comply with the following instructions:

- Ensure that the insulation of electrical cables is not damaged. Avoid: chafing, kinking, jamming or exposure to heat.
- In waterproof connectors, seal any connector chambers not in use with filler plugs to ensure they are dirt-proof and water-proof.
- Electrical connections and ground connections must be free of corrosion and firmly connected.
- Lubricate connections and ground connections outside the heater interior with contact grease.

Please note!

Comply with the following when wiring the heater and the control element:

- Electrical leads, switchgear and controllers must be arranged in the vehicle so that they can function perfectly under normal operating conditions (e.g. heat exposure, moisture etc.).
- The following cable cross sections are to be used between the battery and heater. This ensures that the max. tolerable voltage loss in the cables does not exceed 0.5 V for 12 V or 1 V for 24 V rated voltage.
Cable cross sections for a cable length of
– up to 5 m (plus cable + minus cable) =
cable cross section 4 mm²
– from 5 to 8 m (plus cable + minus cable) =
cable cross section 6 mm²
- If the plus cable is to be connected to the fuse box (e.g. terminal 30), the vehicle cable from the battery to the fuse box must be included in rating the overall cable length and possibly re-dimensioned if necessary.
- Insulate unused cable ends.

Parts list for the circuit diagrams

The circuit diagrams are printed at the end of this manual.

Parts list for the circuit diagram

- 1.1 Burner engine
- 1.2 Glow plug
- 1.5 Overheating sensor
- 1.7 Printed circuit board with control temperature sensor, speed controller and plug distributor
- 1.12 Flame sensor
- 1.13 Temperature sensor
- 2.1 Controller
- 2.2 Dosing pump
- 2.5.1 Current regulator
- 2.7 main fuse 25 A
- 3.1.12 Fault code query, optional
- 5.1 Battery
- e) To connect the temperature sensor, disconnect the existing plug sleeve housing and connect the plug sleeve housing of the temperature sensor
- g) Connection for operating devices to the heater

Parts list circuit diagrams control elements

- 2.5.4 Closing relay
- 2.5.9 Ventilation relay
- 2.15.1 Temperature sensor (room temperature)
- 2.15.9 Temperature sensor (outside temperature)
- 3.1.11 Control device circular
- 3.1.12 Fault code query, optional
- 3.1.16 Button, radio remote control
- 3.1.18 Button, *CALLTRONIC*
- 3.2.8 Timer (ADR / ADR99 – Potentiometer)
- 3.2.9 Timer, ADR / ADR99
- 3.2.12 Timer, Mini – 12 / 24 Volt
- 3.2.14 Lighting, mini timer – nur 12 Volt
- 3.3.6 Radio remote control stationary part TP41i
- 3.3.7 Radio remote control stationary part TP5
- 3.3.8 Remote control *CALLTRONIC*
- 3.6.1 Cable harness for 3.1.11
- 3.6.5 Cable harness for 3.2.8
- 3.8.1 Relay Timer, 12 Volt / 24 Volt
- 3.8.3 Antenna
- b) Terminal 15
- c) Lighting, terminal 58
- g) Connection for operating devices to the heater
- i) Connection, radio module
- j) Connection, temperature sensor (outside temperature)
- k) External button ON / OFF



5 Electrical system

Parts list for the circuit diagrams

The circuit diagrams are printed at the end of this manual.

Parts list for the circuit diagram ADR / ADR99

- 1.1 Burner engine
- 1.2 Glow plug
- 1.5 Overheating sensor
- 1.7 Printed circuit board with control temperature sensor, speed controller and plug distributor
- 1.12 Flame sensor
- 1.13 Temperature sensor

- 2.1 Controller
- 2.2 Dosing pump
- 2.5.1 Current regulator
- 2.7 main fuse 25 A

- 3.1.6 Button heating
- 3.1.7 Button OFF
- 3.1.12 Fault code query, optional
- 3.4.1 Operation control lamp

- 4.1 ADR/ADR99 controller
- 4.1.1 Relay for ADR/ADR99 device

- 5.1 Battery
- 5.2.1 Battery main switch
(operation, e.g. disconnected via ignition) d)
- 5.2.2 Battery disconnecting switch
(EMERGENCY-OFF-function ADR / ADR99) d)
- 5.3 Auxiliary drive
- 5.3.2 Control lamp auxiliary drive
- 5.3.4 Diode
(when required for decoupling the control lamp of the auxiliary drive)
- 5.5 Dynamo terminal D+

- d) When only one switchgear element is used for 5.2.1 and 5.2.2, it must be ascertained that with the function "open the battery disconnecting switch" (EMERGENCY-OFF-function ADR / ADR99) the switch opens immediately (without any consideration of the state of the heater) and disconnects all heater circuits from the battery.

- e) To connect the temperature sensor, disconnect the existing plug sleeve housing and connect the plug sleeve housing of the temperature sensor.

- g) Connection for operating devices to the heater.

Parts list circuit diagrams control elements ADR / ADR99

- 3.1.11 Control device circular
- 3.1.12 Fault code query, optional
- 3.6.1 Cable harness for 3.1.11

- c) Lighting, terminal 58
- g) Connection for operating devices to the heater
- h) Connection of timer not allowed

Cable colours

- rt = red
- bl = blue
- ws = white
- sw = black
- gn = green
- gr = grey
- ge = yellow
- vi = violet
- br = brown
- li = purple

Please note!

Insulate any cable ends not being used. Connectors and bush housings are shown from the cable inlet side.

6 Troubleshooting / Maintenance / Service

When faults occur, please check the following:

- If the heater does not start after being switched on:
 - Switch the heater off and on again.
- If the heater still does not start, check whether:
 - there is fuel in the tank?
 - the fuses are OK?
 - the electrical cables, connections etc. are OK?
 - anything is clogging the combustion air supply or exhaust system?

Troubleshooting

If the heater remains faulty even after these points have been checked, or another malfunction occurs in your heater, please contact:

- for installation ex works, your contract workshop.
- for subsequent installation, the workshop who installed your heater.

Please note!

Please note that warranty claims can become void if the heater is changed by a third party or by this installation of third party parts.

Maintenance instructions

- Switch the heater on once a month for about 10 minutes, even outside the heating period.
- Before the heating period starts, the heater should undergo a trial run.
If persistent extreme smoke develops, unusual burning noises or a clear fuel smell can be perceived or if electric/electronic parts heat up, the heater must be switched off and put out of service by removing the fuse.
In this case, the heater should not be started up again until it has been checked by qualified staff who have been trained on Eberspächer heaters.
- Check the openings of the combustion air supply and exhaust system after longer standstill periods, clean if necessary!

Service

If you have any technical queries or problems with your heater, dial the following service phone number:

Hotline
Phone. 00 49 (0)800 / 12 34 300

Fax hotline
Fax 00 49 (0)1805 / 26 26 24



7 Environment

Certification

The high quality of Eberspächer's products is the key to our success.

To guarantee this quality, we have organised all work processes in the company along the lines of quality management (QM).

Even so, we still pursue a large number of activities for continuous improvement of product quality in order to keep pace with the similarly constantly growing requirements made by our customers.

All the steps necessary for quality assurance are stipulated in international standards.

This quality is to be considered in a total sense.

It affects products, procedures and customer/supplier relationships.

Officially approved public experts assess the system and the corresponding certification company awards a certificate.

Eberspächer has already qualified for the following standards:

**Quality management as per
DIN EN ISO 9001:2000 and ISO/TS 16949:1999**

**Environment management system as per
DIN EN ISO 14001:1996**

Disposal

Disposal of materials

Old devices, defect components and packaging material can all be separated and sorted into pure-grade fractions so that all parts can be disposed of as required in an environment-friendly manner or recycled where applicable.

Electric motors, controllers and sensors (e.g. temperature sensors) are deemed to be "electronic scrap".

Dismantling the heater

The heater is dismantled according to the repair stages in the current troubleshooting/repair instructions.

Packaging

The packaging of the heater can be kept in case it has to be sent back.

EU Declaration of Conformity

With regard to the following products

air heater type 5 L

we herewith confirm that it conforms with the prime safety requirements stipulated in the directives of the EU Council for harmonisation of the legal regulations of the member states with regard to electromagnetic compatibility (89 / 336 / EEC).

This declaration applies to all heaters produced according to the production drawings D 5 L C which are an integral part of this declaration.

The following standards/directives have been used to assess the product with regard to electromagnetic compatibility:

- EN 50081 – 1 Basic form interference emission
- EN 50082 – 1 Basic form interference resistance
- 2 / 245 / EEC – Modification status 95 / 54 / EU interference suppression in motor vehicles

8 Lists

List of key words A – Z

Keyword	Page	Keyword	Page
A			
Accident prevention	7	Instructions	4, 5
ADR / ADR99	12, 27	Installation	12 – 24
Ambient temperature	10	Installation area	12, 13
C			
Certificates	31	Interference suppression class	10
Circuit diagrams (at the end of the manual)		Initial commissioning	25
Combustion air system	19	Installation location	12, 13
Control devices	25	Installation position	14
Control in heating mode	26	Index	32, 33
Contents	2	Information	4
D			
Dangerous goods	12, 27	L	
Declaration of conformity	31	Lists	32, 33
Description of functions	26	List of key words	32, 33
Disposal	31	List of special terms	33
Dosing pump	20 – 23	List of abbreviations	33
E			
Electronic components	29	M	
Emergency off	27	Maintenance	30
Emergency stop	27	Main dimensions	11
Environment protection	31	N	
EU Declaration of Conformity	31	Nameplate	16
Extra parts	8	Noise emission	10
Exhaust	18	O	
Exhaust system	18	Operation	25
F			
Faults	30	Operating instructions	25
Fastening	15	P	
Fan operation	26	Picture symbols	4
Forced shut-down	27	Power consumption	10
Formation of air bubbles	20	Pressure height	23
Fuel	5, 20 – 24	Pressure side	21, 22
Fuel withdrawal	20 – 24	Presentation	4
Fuel system	20 – 24	Purpose	4
Fuel quality	24	R	
H			
Heat flow	10	Rated voltage	10
Heating operation	26	Regulations	5, 6
Heater air system	17	S	
Hotline	30	Safety devices	27
		Safety check (before starting)	25
		Scope of supply	8, 9
		Storage temperature	10
		Statutory regulations	5, 6
		Start procedure	25
		Suction height	23
		Switching on	26
		Switching off	26



8 Lists

List of key words A – Z

Keyword	Page
T	
Technical data	10
Test symbol	5
Text structure	4
T-piece	21
Transport	12
Troubleshooting	30
U	
Use	4
V	
Voltage	10
Voltage limit	10
W	
Weight	10
Wiring	28

List of abbreviations

ADR

European agreement about the international transport of dangerous goods on the road.

ADR99

Dangerous goods regulations for France.

EU Type Permit

Permit awarded by the Federal Vehicle Office for the production of a heater for installation in motorised vehicles.

EMC directive

Electromagnetic compatibility.

JE partner

J. Eberspächer partner.

PME

Biodiesel as per DIN V 51606.



Circuit diagram air heater 5 L Schéma des connexions Appareil de chauffage à air 5 L

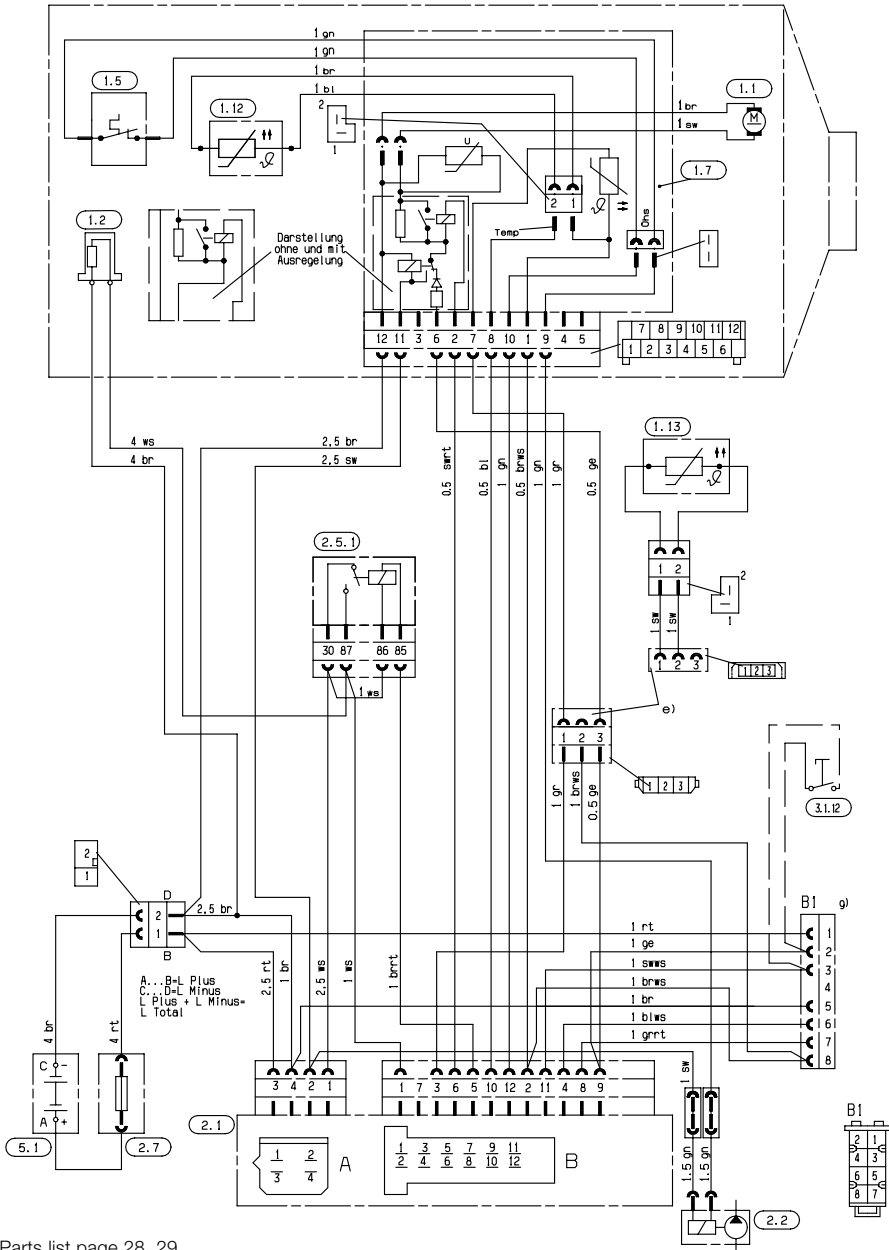

Parts list page 28, 29
Liste des pièces, pages 28, 29

25 1830 00 96 01 A

EN

FR

Circuit diagram – controls part 1

Schéma des connexions Eléments de commande – partie 1

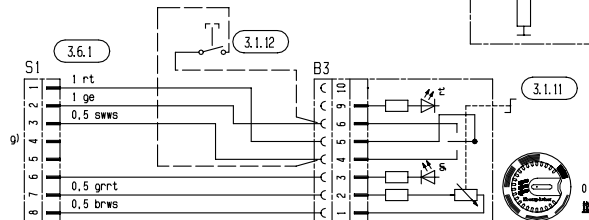
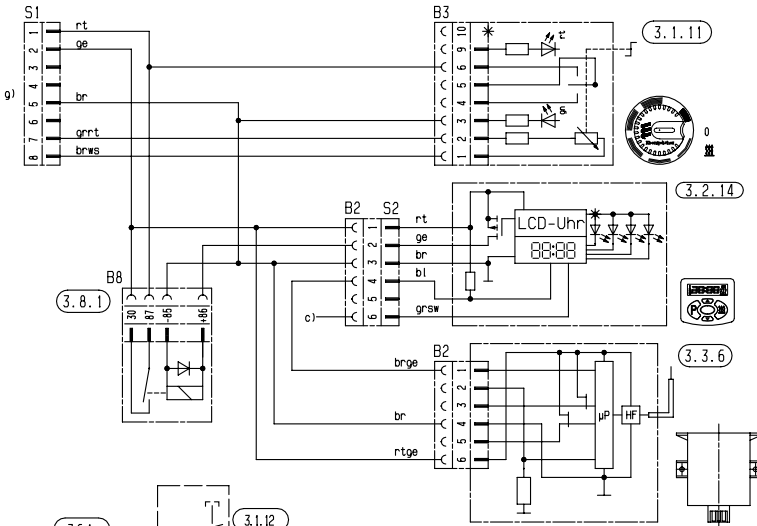
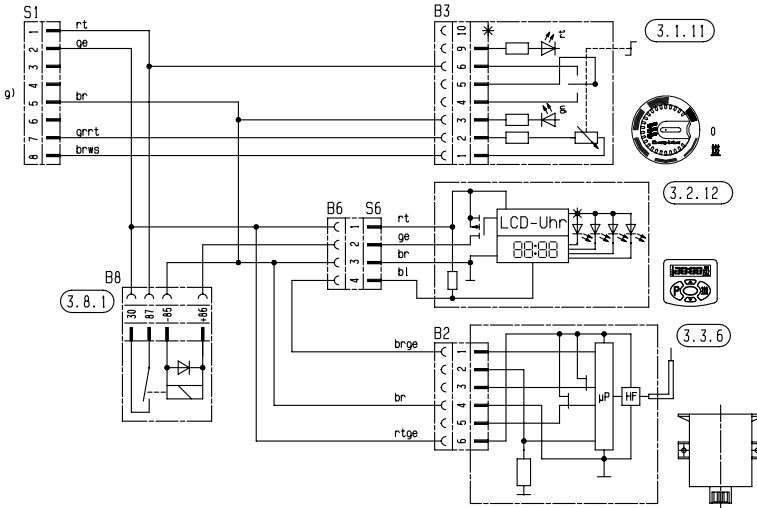

EN

FR

Parts list page 28, 29
Liste des pièces, pages 28, 29

25 1822 00 97 01 G

Circuit diagram – controls part 2

Schéma des connexions Eléments de commande – partie 2

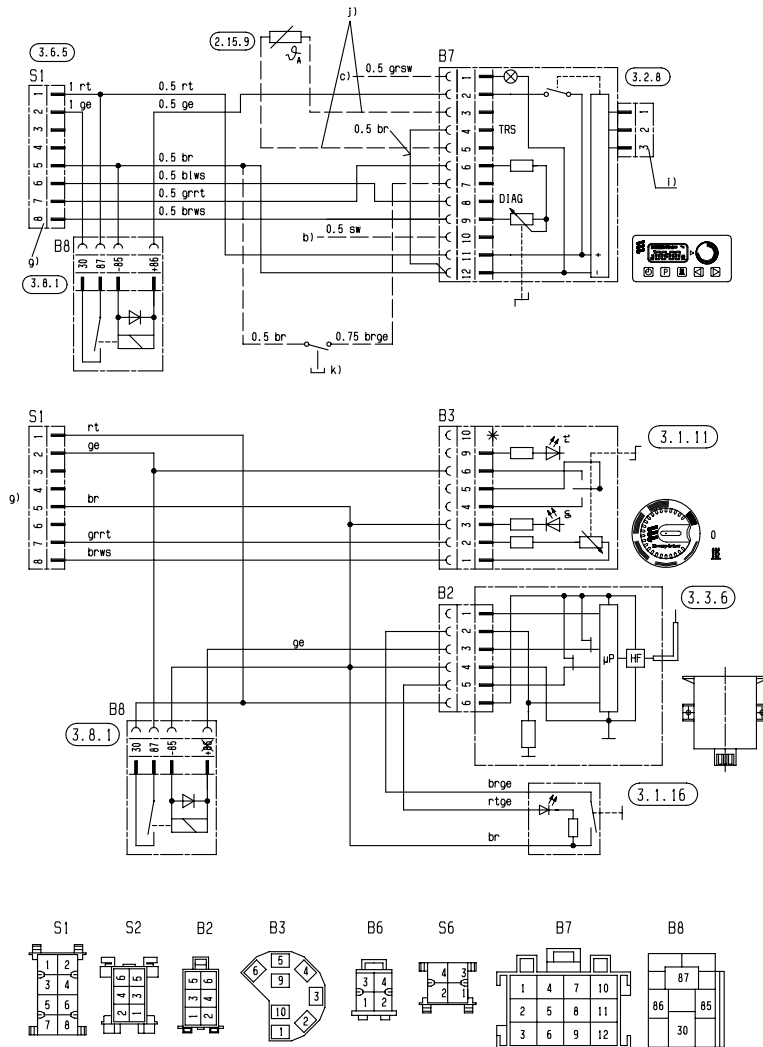

Circuit diagram – controls part 3

Schéma des connexions Eléments de commande – partie 3

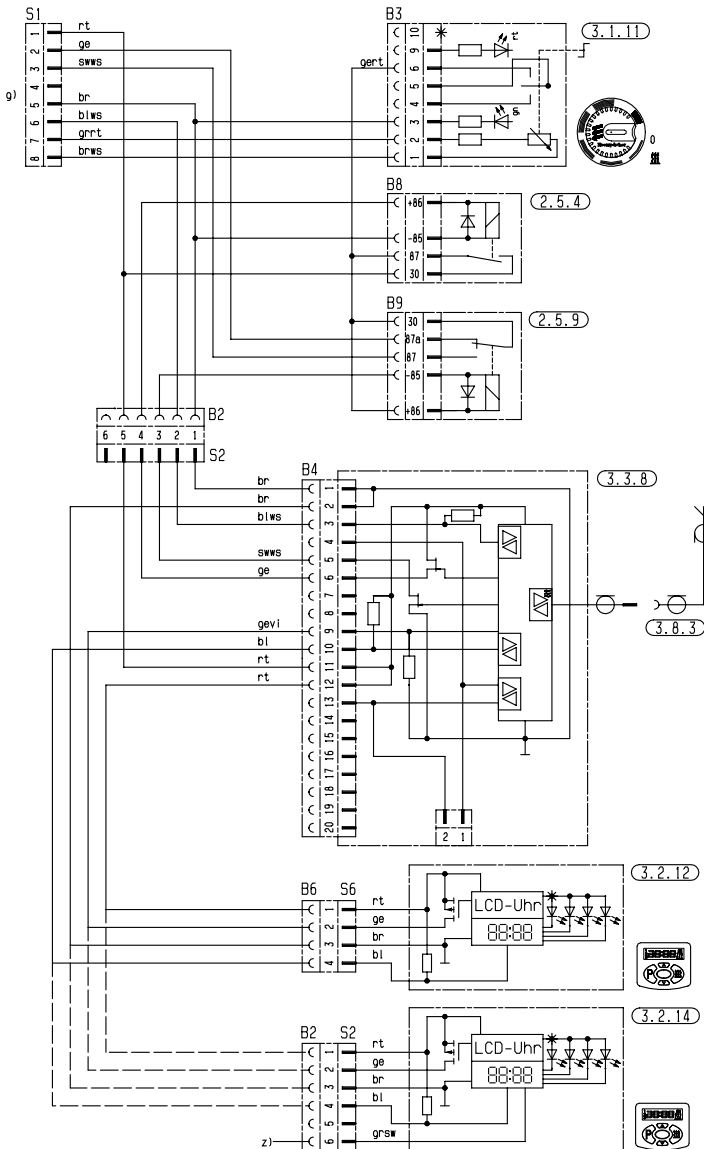

EN

FR

Circuit diagram – controls part 4 Schéma des connexions Eléments de commande – partie 4

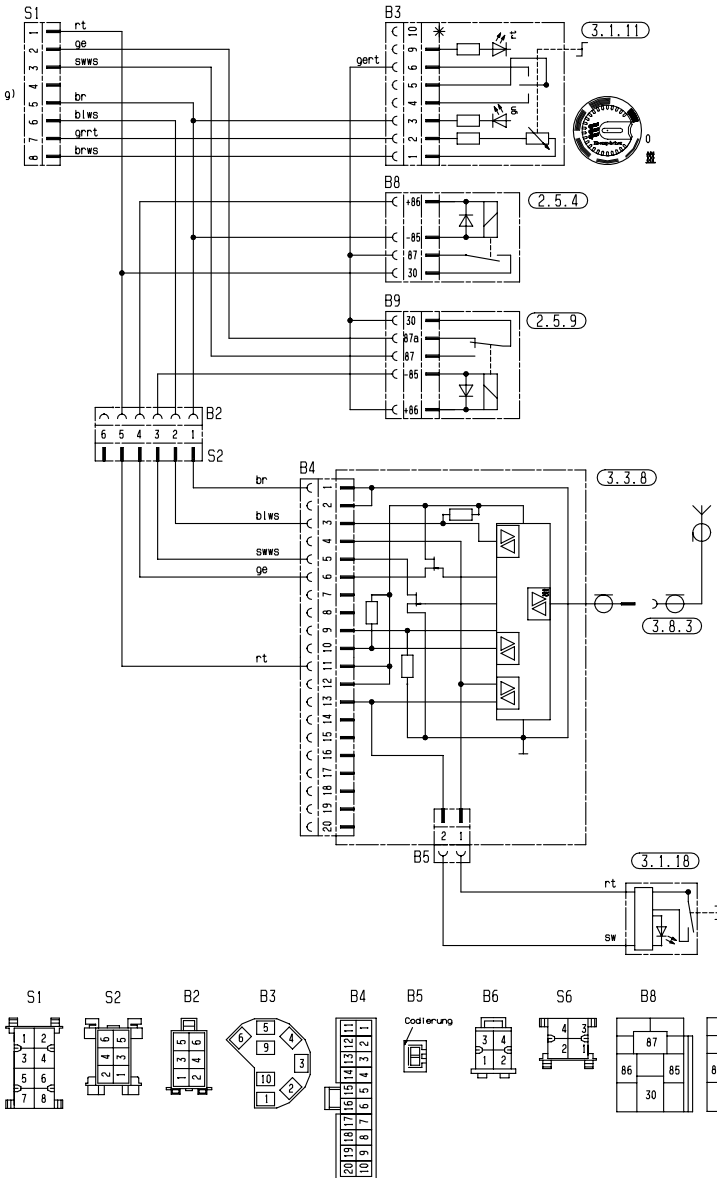

Parts list page 28, 29
Liste des pièces, pages 28, 29

25 1822 00 97 03 A

EN

FR

Circuit diagram – controls part 5
Schéma des connexions Eléments de commande – partie 5

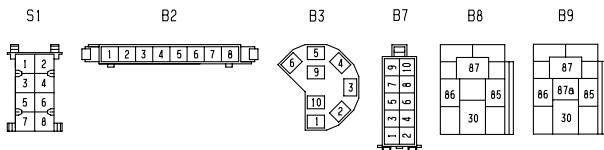
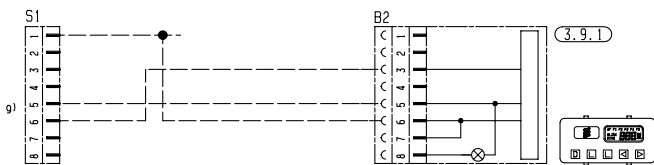
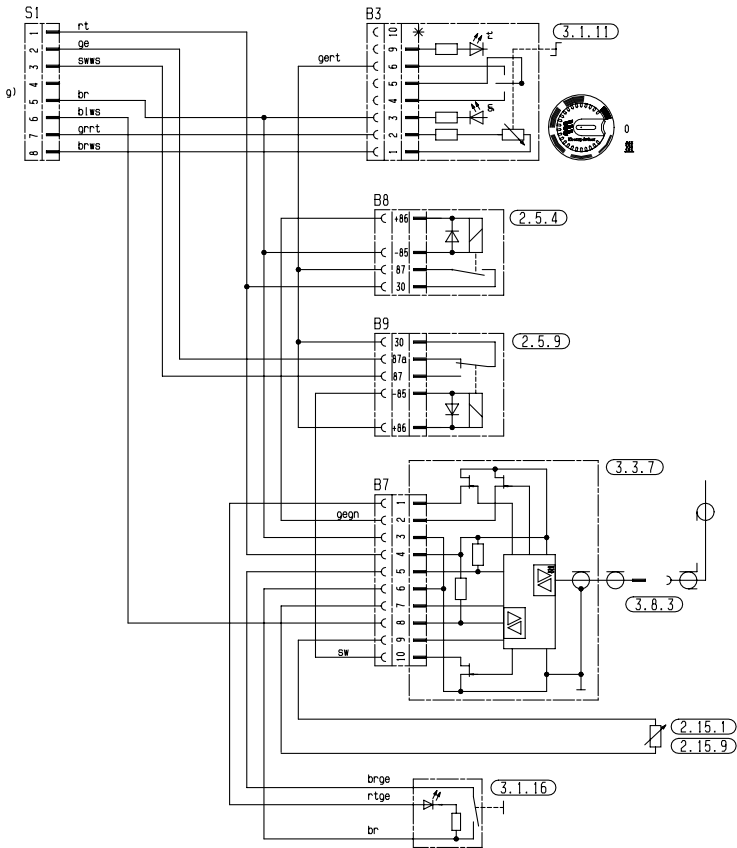

Parts list page 28, 29
 Liste des pièces, pages 28, 29

25 1822 00 97 04 B

Circuit diagram air heater ADR / ADR99
Schéma des connexions Appareil de chauffage à air ADR / ADR99

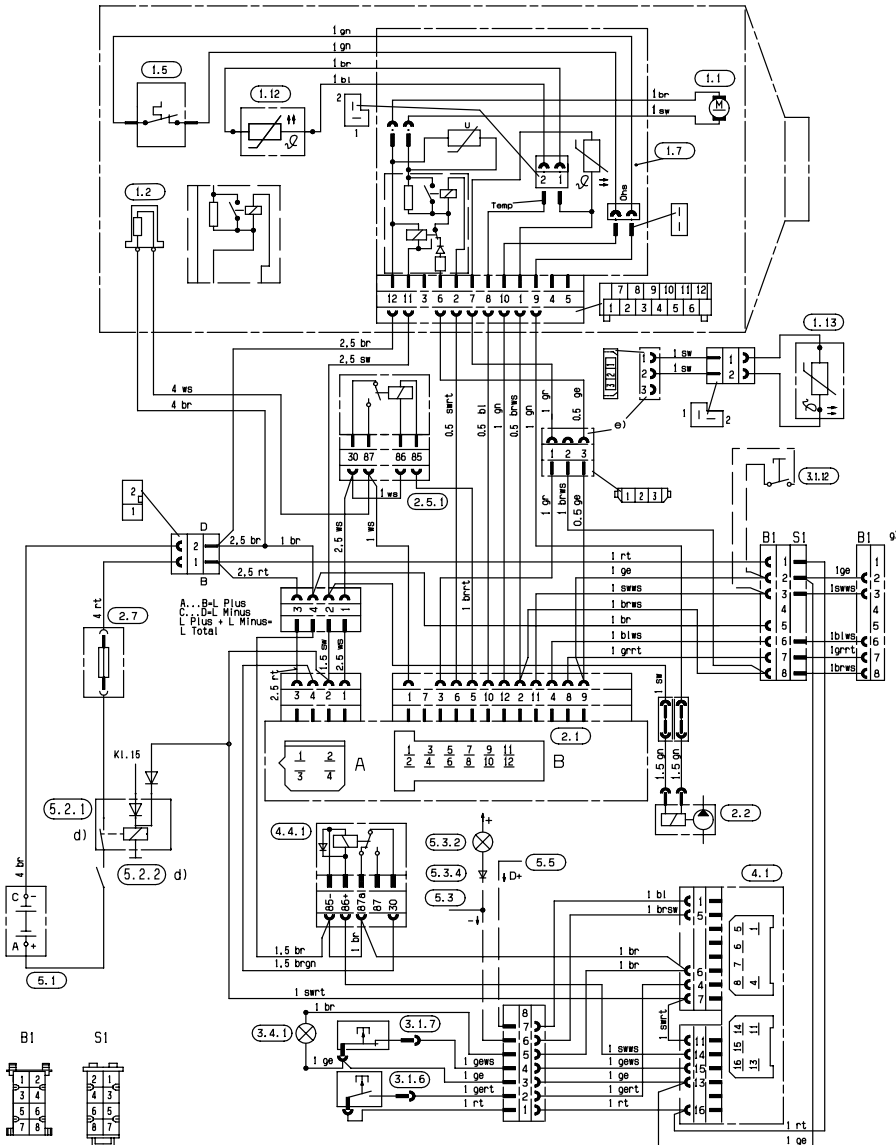

Circuit diagram – controls part ADR / ADR99
Schéma des connexions Eléments de commande ADR / ADR99

